

Rapid Prototyping - Technology to Shorten the Product Design and Development Process

By

¹Prof. Priyanka Mahendru and ²Prof. D.V.Mahindru

Abstract— The term “Rapid Prototyping” (RP) refers to a class of technologies that can automatically construct physical models from computer-Aided Design (CAD) data or is a group of techniques used to quickly fabricate a scale model of a physical part or assembly using three-dimensional computer aided design (CAD) data. The “three dimensional printers” allow designers to quickly create tangible prototypes of their designs rather than two dimensional pictures. Such models have numerous uses. They make excellent visual aids for communicating ideas with co-workers or customers apart from design testing. For example Aerospace Engineer might mount a model aerofoil in a wind tunnel to measure lift and drag forces. Across the world, Engineering has the common language and common goal-“Improving the Quality of Life” of mankind without any boundary restrictions. To bring about this much needed change, we require the services of the fraternity of Engineers to work on the challenges posed by our times. The need of the hour is to bring together globally this fraternity to collaborate with each other. India has ample opportunities and challenges and the massive advances made by us in Science and Technology need transformation by the frantic pace of market dynamics. What we need today is “Change Leaders” to bring about innovation, growth and a totally new work culture.

¹Prof. Priyanka Mahendru, Asstt. Professor (E&C),
E.I.Deptt., SRMGPC, Tewari Ganj,
Lucknow-227 105 U.P. India (Tel: 0522 2351113,
(e-mail:dvmahindru@yahoo.com)

² Prof. D.V.Mahindru, Professor (Mech Engg), Mech
Engg Deptt., SRMGPC, Tewari Ganj, Lucknow-227 105
U.P. India (Tel: 0522 2351113,
(e- mail:dvmahindru@yahoo.com)

The Rapid Prototyping is one such remarkable technology that is revolutionizing the manufacturing process. The Prototype techniques can also be used

to make tooling referred to as rapid tooling and even production of quality parts (rapid manufacturing). Designers have always used “Prototypes” and RP allows them to be made faster and less expensive. For small production runs and complicated objects, rapid prototyping is often the best manufacturing process available. The rapid is a relative term. Most prototypes require from **three to seventy two hours** to build depending upon the size and complexity of the object. This may seem slow but is much faster than the weeks and months/years required to make prototypes by traditional means such as machining. This dramatic time saving technique allows the manufacturers to bring products to market faster and cheaper. In 1994, Pratt and Whitney achieved an order of cost reduction and time saving of 70 to 90 percent by incorporating rapid prototyping into their investment casting process. Rapid Prototyping is a “Additive Process” combining layers of paper, wax or plastic to create a solid object whereas most machining processes (milling, turning, drilling, grinding etc) are “Subtractive Processes” that remove material from solid block. RP’s additive nature allows it to create objects with complicated internal features that cannot be manufactured by other means. For certain applications, particularly metals, machining will continue to be a useful manufacturing process.

Rapid prototyping will not make machining obsolete, rather complement it. This technology is mainly used to shorten the Design and Development process. This acts as a panacea to meet the global competition especially in the industries like aerospace, automotive, jewelry, coin making, tableware, saddletrees, biomedical etc. It is used to fabricate concept models, functional models, patterns for investment and vacuum casting, medical models and models for engineering analysis (Pham and Demov, 2001).

Keywords —Additive, Investment casting, Manufacturing, Prototype, Rapid, Subtractive

1.Introduction :

RP stands for *rapid prototyping* and this in turn refers to as a group of techniques used to quickly fabricate a scale model of a physical part or assembly using three-dimensional computer aided design (CAD) data. It is also known as a class of technologies and is defined, for the purpose of primer, as a 'diverse' set of technological tools and resources that can automatically construct physical models from computer-Aided Design (CAD) data. At least six different rapid prototyping techniques are commercially available, each with unique strengths. As on date RP techniques are being increasingly used in no prototyping applications, these techniques are often collectively referred to as:

Solid free-form fabrication ,computer automated manufacturing or layered manufacturing.

Layered manufacturing actually explains the process used by all manufacturing commercial techniques.

A software package slices the CAD model in to number of thin = 0.1mm thick layers which are then built up one atop another. This is an "Additive Process" rather than most machining processes that are "Subtractive Processes".

The six RP techniques available are as follows:

- Stereo Lithography (SLA).
- Laminated Object Manufacture (LOM)
- Selective Laser Sintering (SLS)
- Fused deposition Modelling (FDM).
- Solid Ground Curing (SGC)
- 3D Ink Jet Printing

2.Description:

o Basic Process:

All the RP techniques employ the same basic five step process. The steps are as follows:

- i. Create a CAD model of the design.
- ii. Convert the CAD model in to STL format.
- iii. Slice the STL model in to thin cross sectional layers.

- iv. Construct the model one layer atop another.
- v. Clean and finish the model.

- **CAD Model Creation:** First the object to be built is modelled using a Computer added (CAD) software package. A large number of software packages are available in the market like PRO/ENGINEER. These tend to represent 3-D models more accurately than the wireframe modelers such as AutoCAD and hence produces very good results. The designer can create a new file expressly for prototyping or may use the existing CAD file. The process is same for all the RP build techniques.
- **Conversion to STL Format:** The various CAD packages use a number of different algorithms to represent solid objects. To establish consistency, the STL (stereolithography, the first RP technique) format has been adopted as the standard of the rapid prototyping industry. The second step, therefore, is to convert the CAD file into STL format. This format represents a three-dimensional surface as an assembly of planar triangles, "like the facets of a cut jewel." ⁶ The file contains the coordinates of the vertices and the direction of the outward normal of each triangle. Because STL files use planar elements, they cannot represent curved surfaces exactly. Increasing the number of triangles improves the approximation, but at the cost of bigger file size. Large, complicated files require more time to pre-process and build, so the designer must balance accuracy with manageability to produce a useful STL file. Since the STL format is universal, this process is identical for all of the RP build techniques.
- **Slice the STL File:** In the third step, a pre-processing program prepares the STL file to be built. Several programs are available, and most allow the user to adjust the size, location and orientation of the model. Build orientation is important for several reasons. First, properties of rapid prototypes vary from one coordinate direction to another. For example, prototypes are usually weaker and less accurate **in the z (vertical) direction than in the x-y plane**. In addition, part orientation partially determines the amount of time required to build the model. Placing the shortest dimension in the z direction reduces the number of layers, thereby shortening build time. The pre-processing software slices the STL model into a number of layers from 0.01 mm to 0.7 mm thick, depending on the build technique. The program may also generate an auxiliary structure to support the model during the build. Supports are useful for delicate features such as overhangs, internal cavities, and thin-walled sections. Each PR machine

manufacturer supplies their own proprietary pre-processing software.

- **Layer by Layer Construction:** The fourth step is the actual construction of the part. Using one of several techniques (described in the next section) RP machines build one layer at a time from polymers, paper, or powdered metal. Most machines are fairly autonomous, needing little human intervention.
- **Clean and Finish:** The final step is post-processing. This involves removing the prototype from the machine and detaching any supports. Some photosensitive materials need to be fully cured before use. Prototypes may also require minor cleaning and surface treatment. Sanding, sealing, and/or painting the model will improve its appearance and durability.

3. Rapid Prototyping Techniques: Most commercially available rapid prototyping machines use one of six techniques. At present, trade restrictions severely limit the import/export of rapid prototyping machines, so this guide only covers systems available in the U.S.

3.1 Stereolithography: Patented in 1986, stereolithography started the rapid prototyping revolution. The technique builds three-dimensional models from liquid photosensitive polymers that solidify when exposed to ultraviolet light. As shown in the figure below, the model is built upon a platform situated just below the surface in a vat of liquid epoxy or acrylate resin. A low-power highly focused UV laser traces out the first layer, solidifying the model's cross section while leaving excess areas liquid.

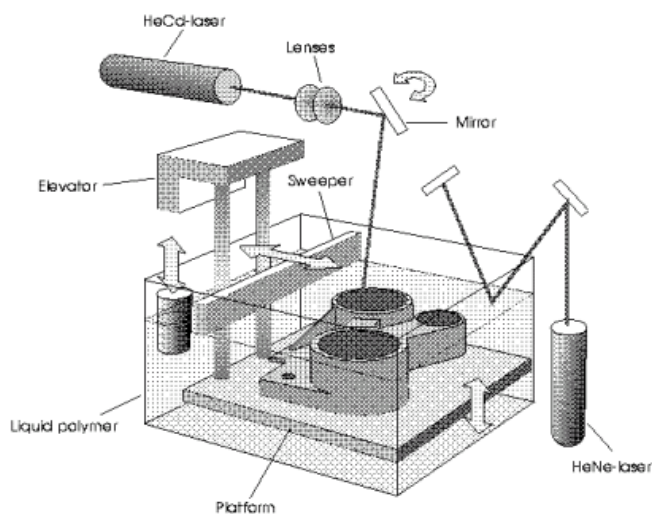

Figure 1: Schematic diagram of stereolithography.

Next, an elevator incrementally lowers the platform into the liquid polymer. A sweeper re-coats the solidified layer with liquid, and the laser traces the second layer atop the first. This process is repeated until the prototype is complete. Afterwards, the solid part is removed from the vat and rinsed

clean of excess liquid. Supports are broken off and the model is then placed in an ultraviolet oven for complete curing. Stereolithography Apparatus (SLA) machines have been made since 1988 by 3D Systems of Valencia, CA. To this day, 3D Systems is the industry leader, selling more RP machines than any other company. Because it was the first technique, stereolithography is regarded as a benchmark by which other technologies are judged. Early stereolithography prototypes were fairly brittle and prone to curing-induced warpage and distortion, but recent modifications have largely corrected these problems.

3.2 Laminated Object Manufacturing: In this technique, developed by Helisys of Torrance, CA, layers of adhesive-coated sheet material are bonded together to form a prototype. The original material consists of paper laminated with heat-activated glue and rolled up on spools. As shown in the figure below, a feeder/collector mechanism advances the sheet over the build platform, where a base has been constructed from paper and double-sided foam tape. Next, a heated roller applies pressure to bond the paper to the base. A focused laser cuts the outline of the first layer into the paper and then cross-hatches the excess area (the negative space in the prototype). Cross-hatching breaks up the extra material, making it easier to remove during post-processing. During the build, the excess material provides excellent support for overhangs and thin-walled sections. After the first layer is cut, the platform lowers out of the way and fresh material is advanced. The platform rises to slightly below the previous height, the roller bonds the second layer to the first, and the laser cuts the second layer. This process is repeated as needed to build the part, which will have a wood-like texture. Because the models are made of paper, they must be sealed and finished with paint or varnish to prevent moisture damage.

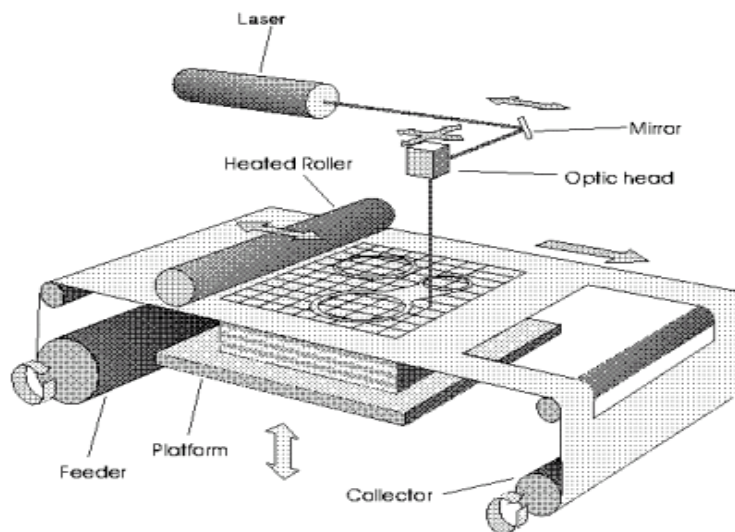

Figure 2: Schematic diagram of laminated object manufacturing.

Helisys developed several new sheet materials, including plastic, water-repellent paper, and ceramic and metal powder tapes. The powder tapes produce a "green" part that must be

sintered for maximum strength. As of 2001, Helisys is no longer in business.

3.3 Selective Laser Sintering:

Developed by Carl Deckard for his master's thesis at the University of Texas, selective laser sintering was patented in 1989. The technique, shown in Figure 3, uses a laser beam to selectively fuse powdered materials, such as nylon, elastomer, and metal, into a solid object. Parts are built upon a platform which sits just below the surface in a bin of the heat-fusible powder. A laser traces the pattern of the first layer, sintering it together. The platform is lowered by the height of the next layer and powder is reapplied. This process continues until the part is complete. Excess powder in each layer helps to support the part during the build. SLS machines are produced by DTM of Austin, TX.

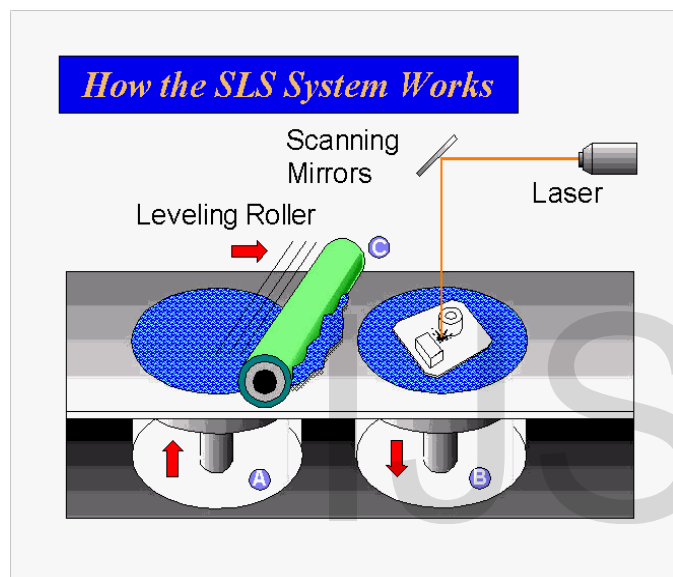

Figure 3: Schematic diagram of selective laser sintering.

3.4 Fused Deposition Modeling:

In this technique, filaments of heated thermoplastic are extruded from a tip that moves in the x-y plane. Like a baker decorating a cake, the controlled extrusion head deposits very thin beads of material onto the build platform to form the first layer. The platform is maintained at a lower temperature, so that the thermoplastic quickly hardens. After the platform lowers, the extrusion head deposits a second layer upon the first. Supports are built along the way, fastened to the part either with a second, weaker material or with a perforated junction.

Stratasys, of Eden Prairie, MN makes a variety of FDM machines ranging from fast concept modelers

to slower, high-precision machines. Materials include ABS (standard and medical grade), elastomer (96 durometer), polycarbonate, polyphenolsulfone, and investment casting wax.

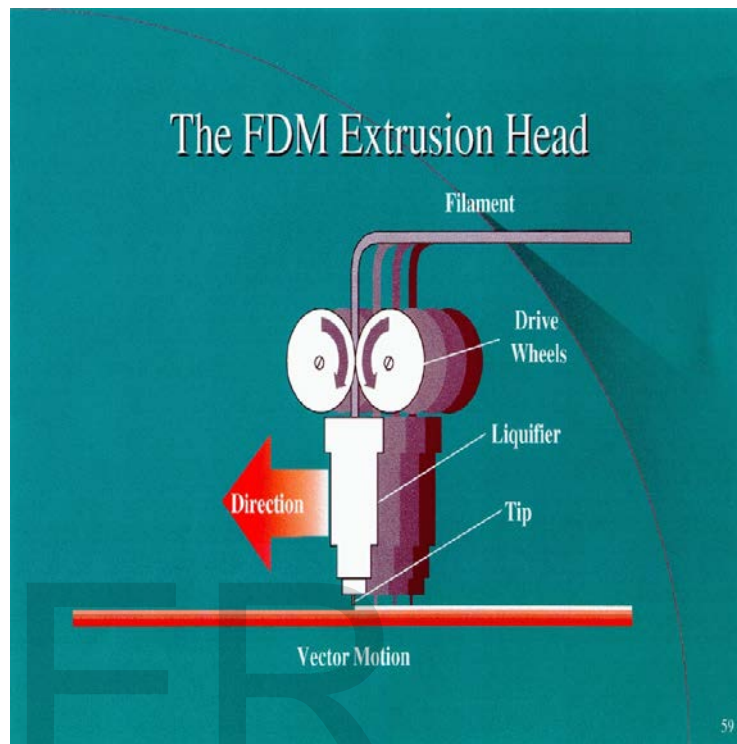

Figure 4: Schematic diagram of fused deposition modeling.

3.5 Solid Ground Curing:

Developed by Cubital, solid ground curing (SGC) is somewhat similar to stereolithography (SLA) in that both use ultraviolet light to selectively harden photosensitive polymers. Unlike SLA, SGC cures an entire layer at a time. Figure 5 depicts solid ground curing, which is also known as the solider process. First, photosensitive resin is sprayed on the build platform. Next, the machine develops a photomask (like a stencil) of the layer to be built. This photomask is printed on a glass plate above the build platform using an electrostatic process similar to that found in photocopiers. The mask is then exposed to UV light, which only passes through the transparent portions of the mask to selectively harden the shape

of the current layer. harden the shape of the current layer.

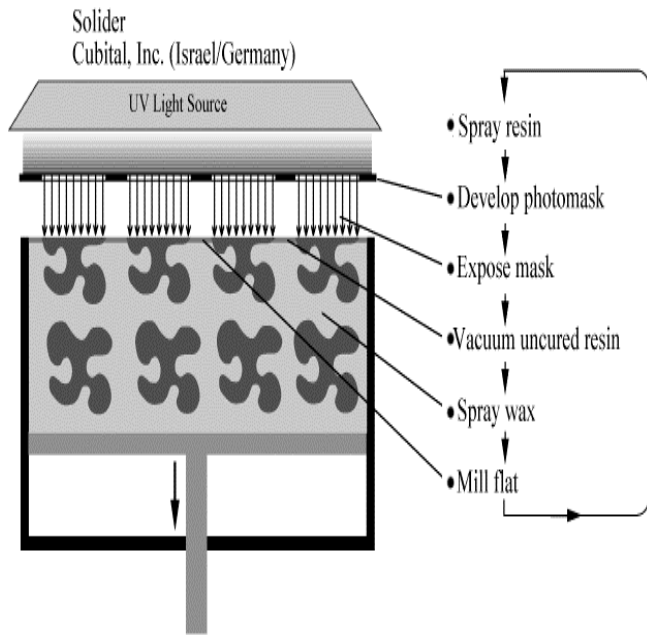

Figure 5: Schematic diagram of solid ground curing.

After the layer is cured, the machine vacuums up the excess liquid resin and sprays wax in its place to support the model during the build. The top surface is milled flat, and then the process repeats to build the next layer. When the part is complete, it must be de-waxed by immersing it in a solvent bath. SGC machines are distributed in the U.S. by Cubital America Inc. of Troy, MI. The machines are quite big and can produce large models.

3.6. 3-D Ink-Jet Printing

Ink-Jet Printing refers to an entire class of machines that employ ink-jet technology. The first was 3D Printing (3DP), developed at MIT and licensed to Soligen Corporation, Extrude Hone, and others. The ZCorp 3D printer, produced by Z Corporation of Burlington, MA (www.zcorp.com) is an example of this technology. As shown in Figure 6a, parts are built upon a platform situated in a bin full of powder material. An ink-jet printing head selectively deposits or "prints" a binder fluid to fuse the powder together in the desired areas. Unbound powder remains to support the part. The platform is lowered, more powder added and leveled, and the process repeated. When finished, the green part is then removed from the unbound powder, and excess unbound powder is blown off. Finished parts can be infiltrated with wax, CA glue, or other sealants to improve durability and surface finish. Typical layer thicknesses are on the order of 0.1 mm. This process is very fast, and produces parts with a slightly grainy surface. ZCorp uses two different materials, a starch based powder (not as strong, but can be burned out, for investment casting applications) and a ceramic powder. 3D Systems' (www.3dsystems.com) version of the ink-jet based system is called the Thermo-Jet or Multi-Jet Printer. It uses a linear

array of print heads to rapidly produce thermoplastic models (Figure 6d). If the part is narrow enough, the print head can deposit an entire layer in one pass. Otherwise, the head makes several passes.

Sanders Prototype of Wilton, NH (www.solid-scape.com) uses a different ink-jet technique in its Model Maker line of concept modelers. The machines use two ink-jets (see Figure 6c). One dispenses low-melt thermoplastic to make the model, while the other prints wax to form supports. After each layer, a cutting tool mills the top surface to uniform height. This yields extremely good accuracy, allowing the machines to be used in the jewelry industry.

Ballistic particle manufacturing, depicted in Figure 6b, was developed by BPM Inc., which has since gone out of business.

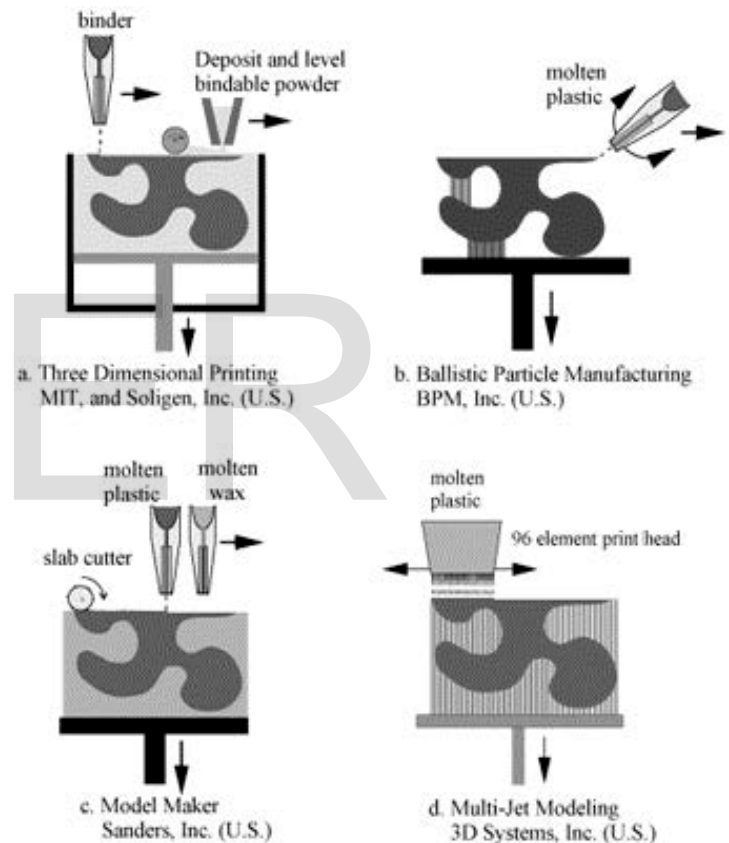

Figure 6: Schematic diagrams of ink-jet techniques.

4. APPLICATIONS OF RP TECHNOLOGIES

RP technology has potential to reduce time required from conception to market up to 10-50 percent (Chua and Leong, 2000) as shown in figure 7. It has abilities of enhancing and improving product development while at the same time reducing costs due to major breakthrough in manufacturing (Chua and Leong, 2000). Although poor surface finish, limited strength and accuracy are the limitations of RP models, it can deposit a part of any degree of complexity theoretically. **Therefore, RP technologies are successfully used by various industries**

like aerospace, automotive, jewelry, coin making, tableware, saddletrees, biomedical etc. It is used to fabricate concept models, functional models, patterns for investment and vacuum casting, medical models and

models for engineering analysis (Pham and Demov, 2001). Various typical applications of RP are summarized in figure 8.

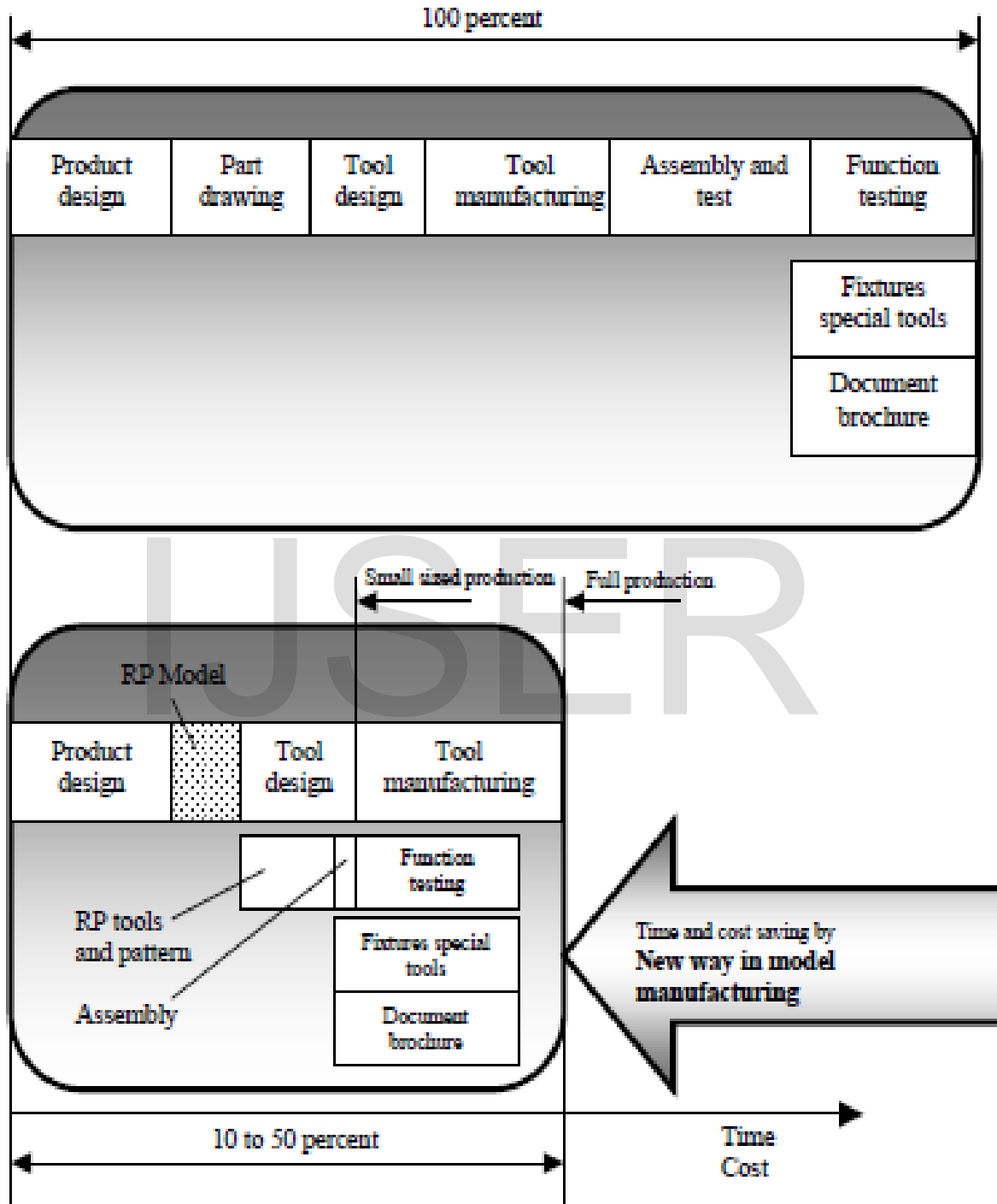

Fig:7 Result of Introduction of RP in Design Cycle

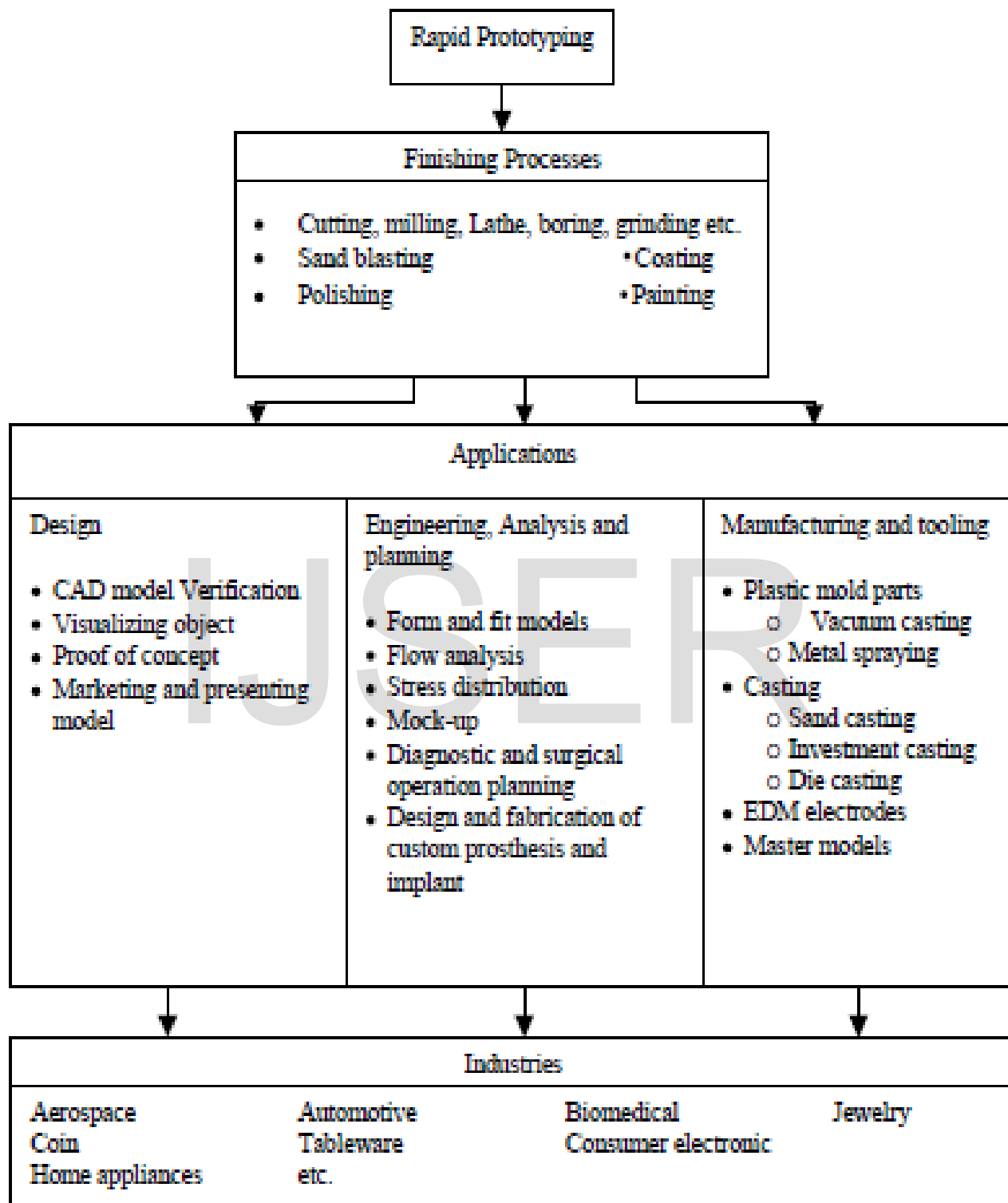

Fig 8: Typical application areas of RP parts

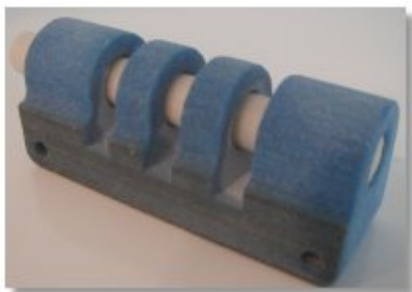

Fig 9: *A prototype sent with a drawing not only creates excitement, but also offers unparalleled clarity.*

❖ **Concept Modeling:**

Create early stage concept models directly from digital data. 3D models enable design teams to efficiently create multiple iterations of product concepts early in the design process. These models enable multiple renditions to be **visualized and critiqued**.

❖ **Finite Element Analysis :**

Parts in color can be used to enhance communication among project teams and aid in the discovery of design flaws early in the design cycle. Clear communication between designers and manufacturers is crucial during the design process, because the discovery of design flaws early in the process prevents unexpected costs and delays.



❖ **Presentation Models:**

Manufacturing companies face the challenge of staying ahead of the competition by delivering innovative products to market quickly. The race to maintain shelf space in major stores requires that companies develop a rapid response to competitive threats. Therefore, collecting valuable market feedback is a crucial step in the design cycle.

RP can rapidly provide cost effective models of your designs to allow your customers to experience the product while still in the design stage and prior to construction of expensive prototypes. Your customer will be able to give recommendations and changes that can rapidly be made to the models for validation. Applications include:

- Concept Modeling
- Finite Element Analysis
- Presentation Models



Presentation models can be used for:

- Focus group testing
- Mock-ups for design review
- Assembly with manufactured parts for a complete prototype

5. Applications of Rapid Prototyping:

Rapid prototyping is widely used in the automotive, aerospace, medical, and consumer products industries. Although the possible applications are virtually limitless, nearly all fall into one of the following categories: prototyping, rapid tooling, or rapid manufacturing.

5.1 Prototyping:

As its name suggests, the primary use of rapid prototyping is to quickly make prototypes for communication and testing purposes. Prototypes dramatically improve communication because most people, including engineers, find three-dimensional objects easier to understand than two-dimensional drawings. Such improved understanding leads to substantial cost and time savings. As Pratt & Whitney executive Robert P. DeLisle noted: "We've seen an estimate on a complex product drop by \$100,000 because people who had to figure out the nature of the object from 50 blueprints

could now see it. Effective communication is especially important in this era of concurrent engineering. By exchanging prototypes early in the design stage, manufacturing can start tooling up for production while the art division starts planning the packaging, all before the design is finalized.

Prototypes are also useful for testing a design, to see if it performs as desired or needs improvement. Engineers have always tested prototypes, but RP expands their capabilities. First, it is now easy to perform iterative testing: build a prototype, test it, redesign, build and test, etc. Such an approach would be far too time-consuming using traditional prototyping techniques, but it is easy using RP.

In addition to being fast, RP models can do a few things metal prototypes cannot. For example, Porsche used a transparent stereolithography model of the 911 GTI transmission housing to visually study oil flow. Snecma, a French turbomachinery producer, performed photoelastic stress analysis on a SLA model of a fan wheel to determine stresses in the blades.

5.2 Rapid Tooling:

A much-anticipated application of rapid prototyping is rapid tooling, the automatic fabrication of production quality machine tools. Tooling is one of the slowest and most expensive steps in the manufacturing process, because of the extremely high quality required. Tools often have complex geometries, yet must be dimensionally accurate to within a hundredth of a millimeter. In addition, tools must be hard, wear-resistant, and have very low surface roughness (about 0.5 micrometers root mean square). To meet these requirements, molds and dies are traditionally made by CNC-machining, electro-discharge machining, or by hand. All are expensive and time consuming, so manufacturers would like to incorporate rapid prototyping techniques to speed the process. Peter Hilton, president of Technology Strategy Consulting in Concord, MA, believes that "tooling costs and development times can be reduced by 75 percent or more" by using rapid tooling and related technologies. Rapid tooling can be divided into two categories, indirect and direct.

5.2.1 Indirect Tooling

Most rapid tooling today is indirect: RP parts are used as patterns for making molds and dies. RP models can be indirectly used in a number of manufacturing processes:

- Vacuum Casting: In the simplest and oldest rapid tooling technique, a RP positive pattern is suspended in a vat of liquid silicone or room temperature vulcanizing (RTV) rubber. When the rubber hardens, it is cut into two halves and the RP pattern is removed. The resulting rubber mold can be used to cast up to 20 polyurethane replicas of the original RP pattern. A more useful variant, known as the Keltool

powder metal sintering process, uses the rubber molds to produce metal tools. Developed by 3M and now owned by 3D Systems, the Keltool process involves filling the rubber molds with powdered tool steel and epoxy binder. When the binder cures, the "green" metal tool is removed from the rubber mold and then sintered. At this stage the metal is only 70% dense, so it is infiltrated with copper to bring it close to its theoretical maximum density. The tools have fairly good accuracy, but their size is limited to under 25 centimeters.

- Sand Casting: A RP model is used as the positive pattern around which the sand mold is built. LOM models, which resemble the wooden models traditionally used for this purpose, are often used. If sealed and finished, a LOM pattern can produce about 100 sand molds.
- Investment Casting: Some RP prototypes can be used as investment casting patterns. The pattern must not expand when heated, or it will crack the ceramic shell during autoclaving. Both Stratasys and Cubital make investment casting wax for their machines. Paper LOM prototypes may also be used, as they are dimensionally stable with temperature. The paper shells burn out, leaving some ash to be removed.

To counter thermal expansion in stereolithography parts, 3D Systems introduced QuickCast, a build style featuring a solid outer skin and mostly hollow inner structure. The part collapses inward when heated. Likewise, DTM sells Trueform polymer, a porous substance that expands little with temperature rise, for use in its SLS machines.

- Injection molding: CEMCOM Research Associates, Inc. has developed the NCC Tooling System to make metal/ceramic composite molds for the injection molding of plastics.¹⁸ First, a stereolithography machine is used to make a match-plate positive pattern of the desired molding. To form the mold, the SLA pattern is plated with nickel, which is then reinforced with a stiff ceramic material. The two mold halves are separated to remove the pattern, leaving a matched die set that can produce tens of thousands of injection moldings.

5.2.2 Direct Tooling:

To directly make hard tooling from CAD data is the Holy Grail of rapid tooling. Realization of this objective is still several years away, but some strong strides are being made:

- RapidTool: A DTM process that selectively sinters polymer-coated steel pellets together to produce a metal mold. The mold is then placed in a furnace where the polymer binder is burned off and the part

is infiltrated with copper (as in the Keltool process). The resulting mold can produce up to 50,000 injection moldings.

In 1996 Rubbermaid produced 30,000 plastic desk organizers from a SLS-built mold. This was the first widely sold consumer product to be produced from direct rapid tooling. Extrude Hone, in Irwin PA, will soon sell a machine, based on MIT's 3D Printing process, that produces bronze-infiltrated PM tools and products.

- Laser-Engineered Net Shaping (LENS) is a process developed at Sandia National Laboratories and Stanford University that can create metal tools from CAD data. Materials include 316 stainless steel, Inconel 625, H13 tool steel, tungsten, and titanium carbide cermets. A laser beam melts the top layer of the part in areas where material is to be added. Powder metal is injected into the molten pool, which then solidifies. Layer after layer is added until the part is complete. Unlike traditional powder metal processing, LENS produces fully dense parts, since the metal is melted, not merely sintered. The resulting parts have exceptional mechanical properties, but the process currently works only for parts with simple, uniform cross sections. The system has been commercialized by MTS corporation (www.mts.com).
- Direct AIM (ACES Injection Molding): A technique from 3D Systems in which stereolithography-produced cores are used with traditional metal molds for injection molding of high and low density polyethylene, polystyrene, polypropylene and ABS plastic. Very good accuracy is achieved for fewer than 200 moldings. Long cycle times (~ five minutes) are required to allow the molding to cool enough that it will not stick to the SLA core.

In another variation, cores are made from thin SLA shells filled with epoxy and aluminum shot. Aluminum's high conductivity helps the molding cool faster, thus shortening cycle time. The outer surface can also be plated with metal to improve wear resistance. Production runs of 1000-5000 moldings are envisioned to make the process economically viable.

- LOMComposite: Helysis and the University of Dayton are working to develop ceramic composite materials for Laminated Object Manufacturing. LOMComposite parts would be very strong and durable, and could be used as tooling in a variety of manufacturing processes.
- Sand Molding: At least two RP techniques can construct sand molds directly from CAD data. DTM

sells sand-like material that can be sintered into molds. Soligen (www.3dprinting.com) uses 3DP to produce ceramic molds and cores for investment casting, (Direct Shell Production Casting).

5.3 Rapid Manufacturing:

A natural extension of RP is rapid manufacturing (RM), the automated production of salable products directly from CAD data. Currently only a few final products are produced by RP machines, but the number will increase as metals and other materials become more widely available. RM will never completely replace other manufacturing techniques, especially in large production runs where mass-production is more economical.

For short production runs, however, RM is much cheaper, since it does not require tooling. RM is also ideal for producing custom parts tailored to the user's exact specifications. A University of Delaware research project uses a digitized 3-D model of a person's head to construct a custom-fitted helmet. NASA is experimenting with using RP machines to produce spacesuit gloves fitted to each astronaut's hands. From tailored golf club grips to custom dinnerware, the possibilities are endless.

The other major use of RM is for products that simply cannot be made by subtractive (machining, grinding) or compressive (forging, etc.) processes. This includes objects with complex features, internal voids, and layered structures. Specific Surface of Franklin, MA uses RP to manufacture complicated ceramic filters that have eight times the interior surface area of older types. The filters remove particles from the gas emissions of coal-fired power plants.⁵ Therics, Inc. of NYC is using RP's layered build style to develop "pills that release measured drug doses at specified times during the day" and other medical products.

6. Future Developments

Rapid prototyping is starting to change the way companies design and build products. On the horizon, though, are several developments that will help to revolutionize manufacturing as we know it. One such improvement is increased speed. "Rapid" prototyping machines are still slow by some standards. By using faster computers, more complex control systems, and improved materials, RP manufacturers are dramatically reducing build time. For example, Stratasys recently (January 1998) introduced its FDM Quantum machine, which can produce ABS plastic models 2.5-5 times faster than previous FDM machines. Continued reductions in build time will make rapid manufacturing economical for a wider variety of products.

Another future development is improved accuracy and surface finish. Today's commercially available machines are accurate to ~0.08 millimeters in the x-y plane, but less in the z (vertical) direction. Improvements in laser optics and motor control should increase accuracy in all three directions. In addition, RP companies are developing new polymers that will be less prone to curing and temperature-induced warpage.

The introduction of non-polymeric materials, including metals, ceramics, and composites, represents another much anticipated development. These materials would allow RP users to produce functional parts. Today's plastic prototypes work well for visualization and fit tests, but they are often too weak for function testing. More rugged materials would yield prototypes that could be subjected to actual service conditions. In addition, metal and composite materials will greatly expand the range of products that can be made by rapid manufacturing.

Many RP companies and research labs are working to develop new materials. For example, the University of Dayton is working with Helisys to produce ceramic matrix composites by laminated object manufacturing. An Advanced Research Projects Agency / Office of Naval Research sponsored project is investigating ways to make ceramics using fused deposition modeling. As mentioned earlier, Sandia/Stanford's LENS system can create solid metal parts. These three groups are just a few of the many working on new RP materials.

Another important development is increased size capacity. Currently most RP machines are limited to objects 0.125 cubic meters or less. Larger parts must be built in sections and joined by hand. To remedy this situation, several "large prototype" techniques are in the works. The most fully developed is Topographic Shell Fabrication from Formus in San Jose, CA. In this process, a temporary mold is built from layers of silica powder (high quality sand) bound together with paraffin wax. The mold is then used to produce fiberglass, epoxy, foam, or concrete models up to 3.3 m x 2 m x 1.2 m in size.

At the University of Utah, Professor Charles Thomas is developing systems to cut intricate shapes into 1.2 m x 2.4 m sections of foam or paper. Researchers at Penn State's Applied Research Lab (ARL) are aiming even higher: to directly build large *metal* parts such as tank turrets using robotically guided lasers. Group leader Henry Watson states that product size is limited only by the size of the robot holding the laser.

All the above improvements will help the rapid prototyping industry continue to grow, both worldwide and at home. The United States currently dominates the field, but Germany, Japan, and Israel are making inroads. In time RP will spread to less technologically developed countries as well. With more people and countries in the field, RP's growth will accelerate further.

One future application is Distance Manufacturing on Demand, a combination of RP and the Internet that will allow designers to remotely submit designs for immediate manufacture. Researchers at UC-Berkeley, among others, are developing such a system. RP enthusiasts believe that RP will even spread to the home, lending new meaning to the term "cottage industry." Three-dimensional home printers may seem far-fetched, but the same could be said for color laser printing just fifteen years ago.

7. SUMMARY:

This paper provides an overview of RP technology in brief and emphasizes on their ability to shorten the product design and development process. Classification of RP processes and details of few important processes is given. The description of various stages of data preparation and model building has been presented. An attempt has been made to include some important factors to be considered before starting part deposition for proper utilization of potentials of RP processes.

Finally, the rise of rapid prototyping has spurred progress in traditional subtractive methods as well. Advances in computerized path planning, numeric control, and machine dynamics are increasing the speed and accuracy of machining. Modern CNC machining centers can have spindle speeds of up to 100,000 RPM, with correspondingly fast feed rates. Such high material removal rates translate into short build times. For certain applications, particularly metals, machining will continue to be a useful manufacturing process. Rapid prototyping will not make machining obsolete, but rather complement it.

References:

1. Bralla, J.G. (ed.) (1986), *Handbook of Product Design for Manufacturing*, McGraw-Hill (New York).
2. Brown, J., et al. (eds.) (1992), *PMA Design Guidelines*, Precision Metalforming Assoc..
3. Chua, C.K., Leong, K.F., Kai, C.C. (1998), *Rapid Prototyping Principles and Applications in Manufacturing*, John Wiley and Sons (New York).
4. DeGarmo, E.P., et al. (ed.) (1997), *Materials and Processes in Manufacturing, 8th ed.*, Prentice Hall (Upper Saddle River, NJ).
5. Doyle, L.E., et al. (eds.) (1984), *Manufacturing Processes and Materials for Engineers, 3rd ed.*, Prentice-Hall (Englewood Cliffs, NJ).

6. Kalpakjian, S. (1997), *Manufacturing Processes for Engineering Materials*, Addison Wesley Longman, Inc..
7. Kalpakjian, S. (1993), *Manufacturing Processes for Engineering Materials, 1st ed.*, John Wiley and Sons (New York).
8. Kochan, D. (ed.) (1993), "Solid Freeform Manufacturing: Advanced Rapid Prototyping", *Manufacturing Research and Technology* (19).
9. Kutz, M. (ed.) (1986), *Mechanical Engineers' Handbook*, John Wiley and Sons (New York).
10. Leong, K.F. (1993), *Rapid Prototyping and Manufacturing: Fundamentals of Stereolithography*, McGraw Hill (New York).
11. Oberg, E., Jones, F.D., Horton, H.L., Ryffel, H.H. (1996), *Machinery's Handbook, 25th ed.*, Industrial Press (New York).
12. Rapid Prototyping by William Palm (May 1998), revised 30 July 2002, Penn State Learning Factory.
13. Technical Staff (1997), *Thick Turret Punch Press Tooling*, Mate Precision Tooling (Ramsey, MN). (1998), *Designing Plastic Parts for Assembly, 3rd ed.*, Publishers (Munich).
14. Vlack, L.H. (1985), *Elements of Materials Science and Engineering*, Addison-Wesley (Reading, MA).
15. Chua, C.K., Leong, K.F. (2000), *Rapid Prototyping: Principles and Applications in Manufacturing*, World Scientific.

IJSER